

5G Core Solutions enabled by Casa Systems' Axyom™ Software Platform

Why do we need a 5G core?

When people hear the term 5G, they usually think about the innovations occurring with New Radio (NR). However, 5G also refers to fundamental changes that are occurring within the core network.

The overriding goal of these changes is to help service providers better monetize their networks. This will be achieved by evolving from our current "one size fits all" core network into a 5G core network that provides different logical networks ("slices") for the different traffic requirements.

A few years ago, the industry realized that wireless and wireline core networks were being asked to deliver on a set of requirements that they were not designed to handle. For example, current wireless core networks are designed as a single Evolved Packet Core (EPC) and as a result, they cannot optimally handle the numerous, new traffic flows coming from use cases that are as diverse as the Internet of Things (IoT), Enhanced Mobile Broadband (eMBB) and Mission Critical Services.

The cost, latency, throughput and reliability requirements for each of these use cases is radically different. The industry's solution was to develop a new 5G core network architecture for both wireless and wireline networks that is services based and provides flexibility to deliver unique logical networks, "slices".

Figure 1 **Diverse 5G Use Cases and Network Requirements.**

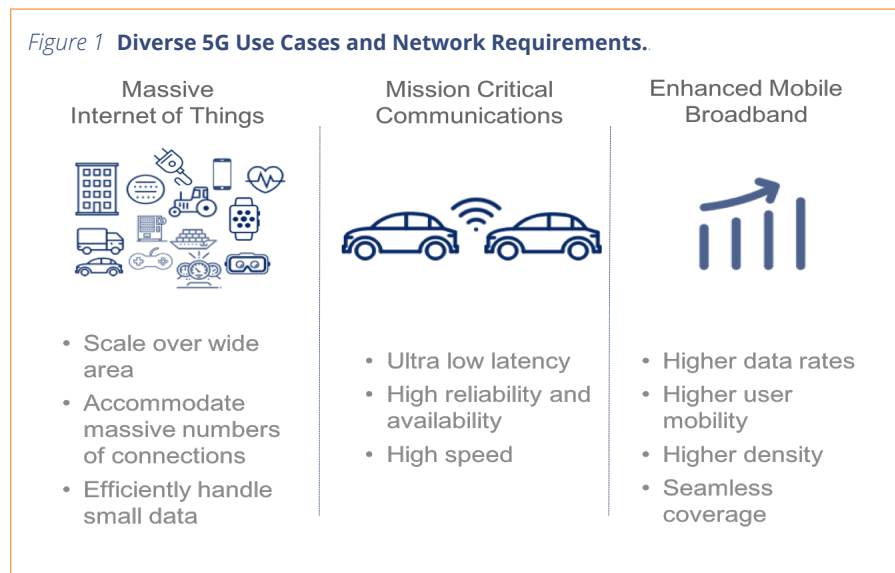

Is your core ready for 5G?

To many people it may seem that their 5G core network purchase decisions are years away. So, why bother thinking about a 5G Core investment now? You should be careful - the choices you are making today may cost you dearly in terms of ongoing 4G network operating costs and lost 5G revenue opportunities. Ongoing spending on a high cost 4G network or spending on 4G capacity that cannot evolve easily to a 5G network could result in regrettable capital spend, inflated operating costs and low profitability.

Casa provides a 4G and 5G Core as part of its Axyom Software Platform. To determine if your current network is ready for 5G you should ask yourself the following questions:

- **Is your Core NFV optimized?**

An optimized 5G or 4G core uses VNFs that are designed from the ground up for peak performance and efficiency in a virtual compute environment. Sadly, most current EPC suppliers virtualized their former appliance-based software using the "lift and shift" model. The result is VNFs that cause incremental latency and vCPU inefficiencies. As a service provider, you will be burdened with too many compute resources, too many servers and too much associated operating expense.

If this poor performance is perpetuated into your 5G core, the result will be extra latency for Mission Critical Services, where every millisecond and even microsecond

count. Also, poorly performing 5G core VNFs will continue to drive additional CPUs which means inflated OPEX costs.

Comparing the Axyom VNF performance against competitors has revealed that Casa's Wireless Core VNFs deliver from 2X to 5X higher Gbps throughput per vCPU and industry-leading number of sessions per vCPU.

- **Is your NFV Implementation flexible?**

Casa's 4G and 5G Cores have the versatility to run on bare metal, virtual machines or in a container-based environment. Current wireless NFV deployments have been implemented using OpenStack and virtual machines. However, Cloud Native design principles from the data center world primarily use containers due to their ability to spin up faster and thus adjust more rapidly to capacity surges.

To ensure that you have a core that is ready for 5G, make sure you are working with a partner, such as Casa, who can support both virtual machines and containers. No one has a crystal ball for the evolution of NFV - staying flexible is critical.

- **Can your 4G Core Implement Control and User Plan Separation (CUPS) today?**

CUPS is inherent in the design of a 5G Core. However, Casa has introduced CUPS today as part of our 4G Core. CUPS provides not only independent scaling of control and user plane, but also allows a service provider to independently locate the control and user plane functions.

Deployable at the network edge or at a centralized location, Casa's Axyom suite

of CUPS-based VNFs are designed to help providers optimize applications and to provide end users with the highest Quality of Experience (QoE). As an example, Mission Critical applications require extremely low latencies that can be achieved by locating both control and user plane functions at the network edge, as close as possible to the end user.

To ensure that you have a core that is ready for 5G, your 4G EPC should be able to implement CUPS today. CUPS is inherent in the 5G core architecture but service providers should be making use of CUPS with 4G now to determine how to best locate control and user plane functions to deliver the needed QoE for each specific user case. CUPS with 4G can also provide NFV infrastructure savings as control and user plane VNFs scale independently.

- **Are you introducing overlay 4G Core networks today that evolve quickly to network slicing tomorrow?**

Network Slicing is one of the pillars of a 5G Core, but a full implementation of network slicing is still a year or two away since it will require the completion of standards and trials.

A core that is ready for 5G must support Network Slicing. Interestingly some of the benefits of network slicing are being achieved today as service providers implement 4G Core overlay cores for IoT and Small Cells. Each of these overlays provide optimized performance that cannot be achieved by the legacy EPC. This demonstrates the clear need for network slicing.

To ensure that you have a 5G Ready Core, start implementing 4G overlay cores, such as Casa's C-SGN for IoT

and Casa's Small Call Core, and realize immediate benefits. It is important to ensure that these 4G overlay cores can elegantly evolve into a 5G core supporting network slicing.

- **Can your Core VNFs scale both vertically and horizontally?**

Casa's 4G and 5G Cores eliminate the performance trade-offs present in many of today's solutions and delivers best-in-class capacity scaling across the following dimensions simultaneously:

- o Throughput per vCPU (with a traffic mix including small packets)
- o Lowest latency
- o Tunnel and session setup rate.

Casa's Axyom Software Platform delivers vertical and horizontal capacity scaling through intelligent pipeline processing, performance acceleration and application of real-time intelligence. It's this kind of engineering that allows Axyom to outperform legacy solutions many times over.

To ensure that you have a core that is ready for 5G, test the ability of your VNFs to scale both horizontally and vertically using the most challenging requirements, such as small packet sizes, security algorithms turned on and high attach / detach rates.

The Axyom Software Platform supports the 5G core

The Axyom Software Platform is a set of disruptive software solutions designed to help service providers transform their broadband networks into a programmable ultra-broadband network. Axyom delivers industry-leading services and cost per bit.

Figure 2 Casa's VNFs for a traditional 4G EPC Implementation

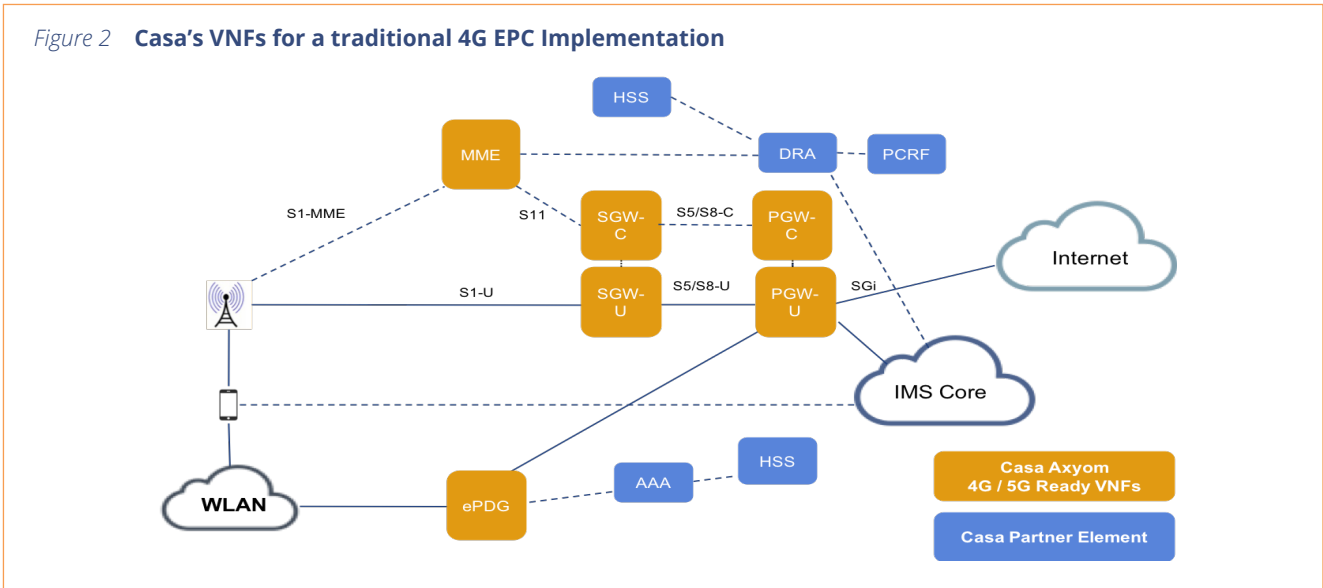

Casa's broadband solutions are anchored by the Axyom Software Platform which handles terabit per second throughputs and has proven stability and advanced routing capabilities.

The figure above shows the Casa 4G Core VNFs for a traditional 4G EPC implementation.

Casa's Overlay Core Network Solutions for IoT and Small Cell Cores

As mentioned earlier, service providers have started to implement 4G overlay core networks for small cells and Cellular IoT (CloT).

For CloT, Casa provides a Cellular IoT Serving Gateway Node (C-SGN) that combines virtualized MME, PGW and SGW functions, is optimized for CloT traffic and can be deployed in containers, VMs or on bare metal. The Casa C-SGN provides a cost-effective and secure overlay core for CloT services (LTE Cat 1-6, M1 & NB-IoT).

The introduction of NB-IoT will result in a significant business opportunity for service providers. NB-IoT will be deployed with sensors whose batteries must last for years in the field. Support of NB-IoT data transfer

over the control rather than the user plane was introduced into 3GPP Release 13 to minimize packet size and thus maximize CloT device battery lifetime. *This capability is not possible without a complete re-architecting of today's inflexible 4G cores / EPCs.*

densification, they are finding that their current EPCs are inflexible and cannot support the additional signaling and traffic from both an economic and a technology perspective. Casa provides a small cell core overlay that can handle the additional load

Figure 3 Cellular IoT Overlay - Casa's C-SGN

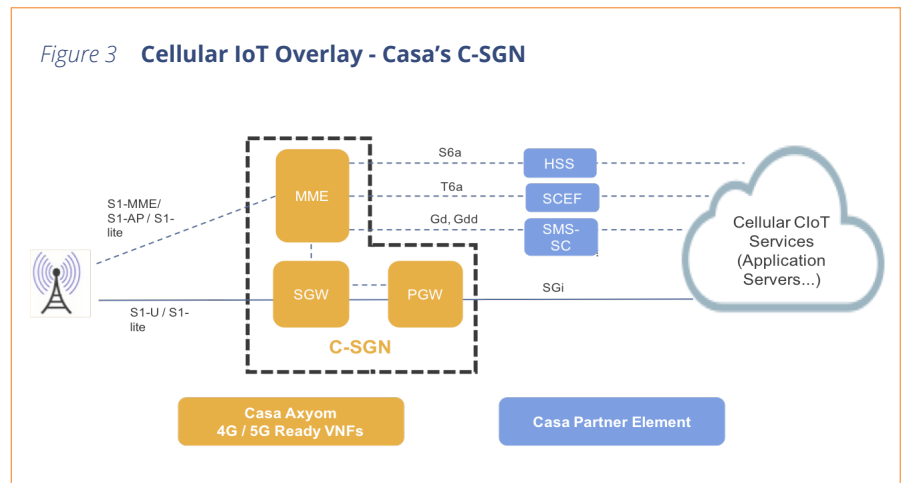

The only alternative is to introduce an overlay CloTcore, such as Casa's C-SGN, to provide full NB-IoT support.

Casa's C-SGN offers industry-leading performance per vCPU. Casa's performance advantage widens when large numbers of secured small IoT packets are transferred.

As service providers add small cells for

but can also manage 3G and 4G small cells from multiple vendors. The Axyom Small Cell Core not only provides the needed capacity, it simplifies small cell deployments for service providers

With the Axyom Small Cell Core, there are several deployment options – Casa can provide a full overlay EPC or can integrate with

Figure 4. Casa's Small Cell Core Overlay

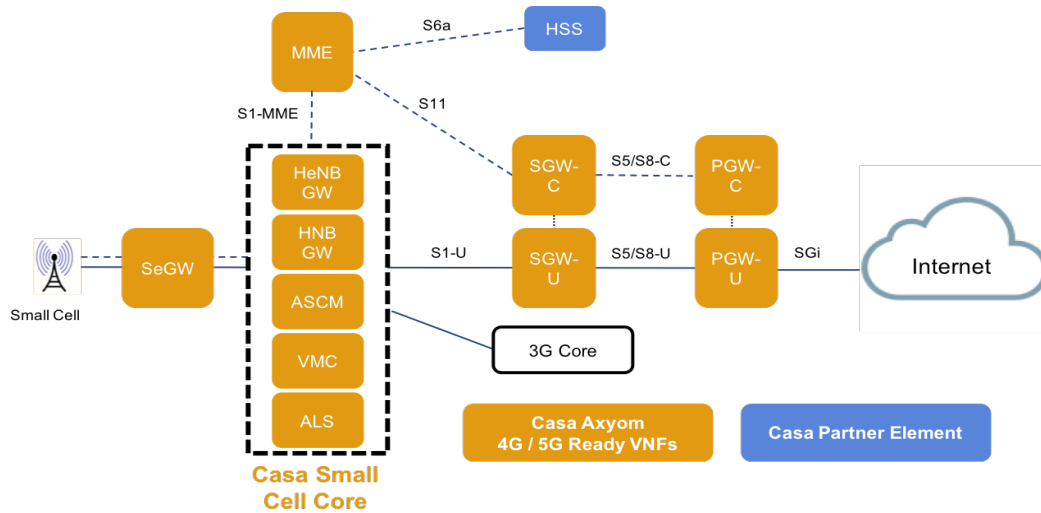

Note: There are a couple of acronyms introduced in this diagram that cannot be found in standards documents:

- Virtual Management Controller (VMC) - A VNF Manager and Element Management System for Casa's Axyom VNFs.
- Axyom Location Server (ALS) - A database storing small cell location information that can be used to fulfill local regulatory requirements, such as emergency calling.
- Axyom Small Cell Manager (ASCM) - The ASCM includes H(e)MS and HMS management for LTE and 3G small cells, real time hybrid SON, TR-069 auto configuration (with TR-196 and TR-181 data models), a Syslog server and KPI performance management. All these management tools are accessed through a single intuitive GUI interface.

an existing EPC. As a further option, a virtual Security Gateway can be provided by Casa.

Since the Casa Small Cell Core is based on the Axyom Software Platform, industry leading density and performance will result in a lower TCO as the service provider densifies their network with small cells.

Evolving to 5G

Today Casa is developing and can demonstrate many of the Axyom Software Platform VNFs that are part of a 5G Core. Casa's 5G Core development goals are to enable programmability, simplicity, scalability, and convergence of wireline and wireless networks.

Using the Axyom Software Platform, Casa's 5G Core delivers:

- Unparalleled Gbps per vCPU – The result is lower OPEX and CAPEX through VNFs that deliver up to 5X higher Gbps

throughput per vCPU and industry-leading number of sessions per vCPU. This translates into lower cost per bit, per user and per session for lower compute resource capital and operating costs.

- A solution deployable in containers, with VMs or on bare metal – This ensures future flexibility as NFV and 5G evolve.
- A smooth migration from 4G to 5G – Casa provides efficient internal messaging between 4G and 5G components (multi-access AMF, SMF and UPF).
- Location-independent placement of the control plane and user plane – Casa fully leverages CUPS not only in 5G but also today in Casa's 4G deployments.
- Network slicing in a service-based architecture.

- 4G Overlay networks for IoT and Small cells today - Service providers can take full advantage of Casa's innovations today by starting now and deploying 4G overlay networks that deliver better performance / efficiency and new capabilities for IoT and Small Cell cores.
- VNFs that scale both vertically and horizontally - Casa's Axyom solution delivers vertical and horizontal capacity scaling via intelligent pipeline processing, performance acceleration and application of real-time intelligence.

Figure 5. The 5G Core

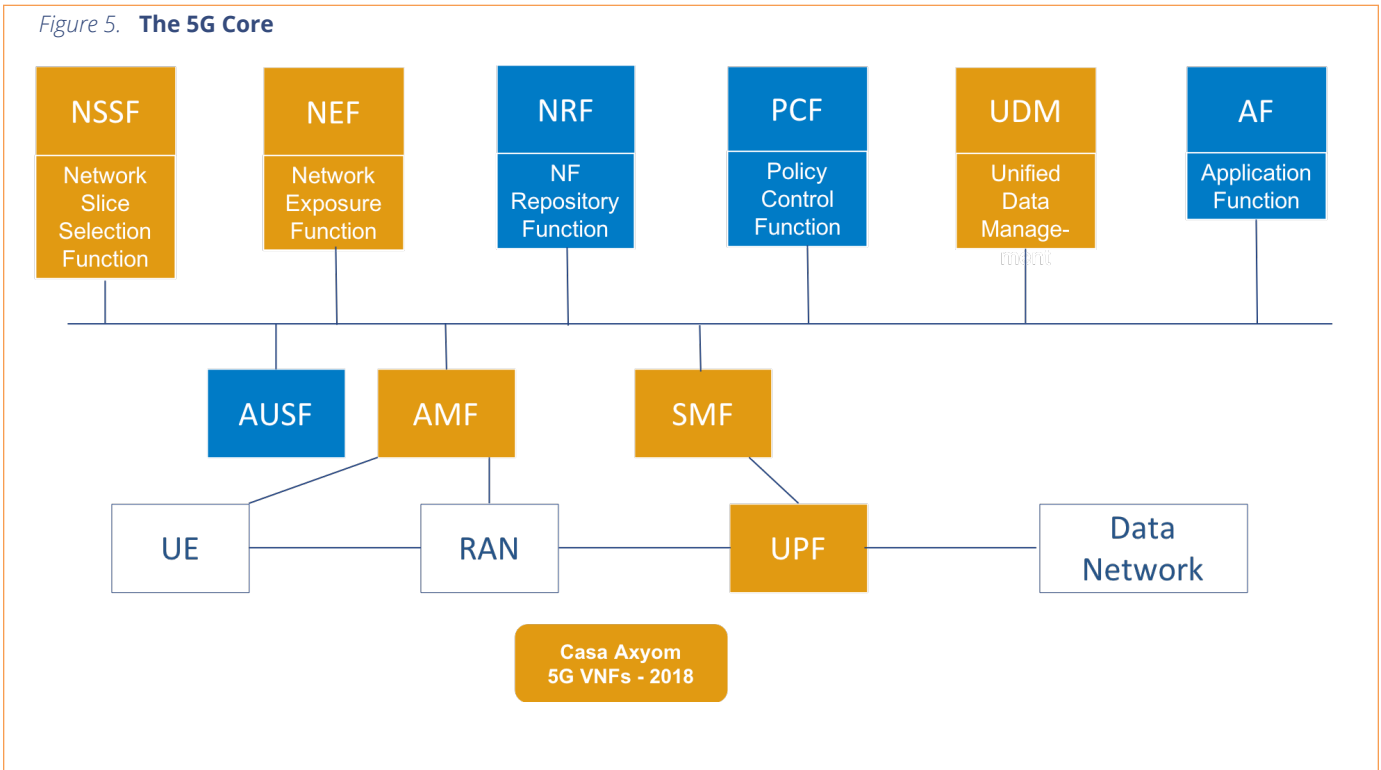

5G provides service providers with an opportunity to optimize and monetize their core networks. Now is the time to start investing in a core that is ready for 5G and avoid regrettable spend on an inflexible, poorly performing 4G-only core. Casa Systems' heritage as a provider of innovative broadband access solutions that incorporate terabit throughputs, software innovation and extreme subscriber management capabilities has resulted in the Axyom 4G and 5G Cores that have been designed from the ground up for flexibility, efficiency and performance.